

# MS05

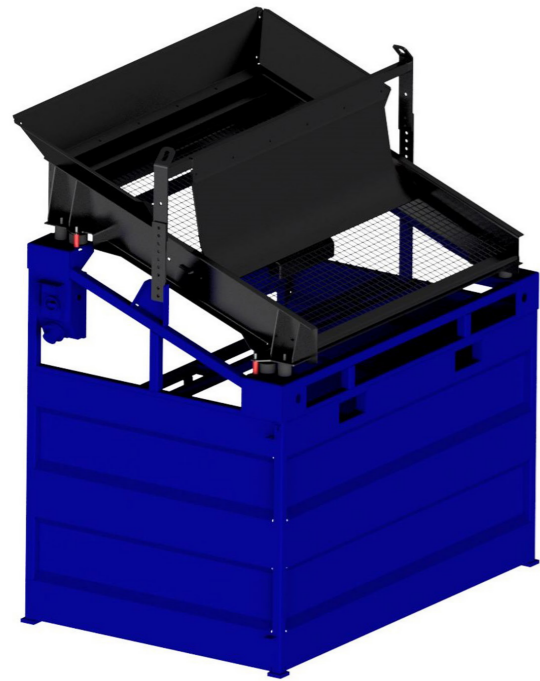

De Flexiever Mini Screener MS05 (220V) is ideaal in combinatie met een mini wiel of kniklader. De machine kan hiermee gemakkelijk beladen en verplaatst worden.

Le Flexiever Mini Screener MS05 (220V) est idéal en combinaison avec une mini chargeuse sur roues ou une chargeuse articulée. La machine peut être facilement chargée et déplacée.

The Flexiever Mini Screener MS05 (220V) is ideal in combination with a mini wheel or articulated loader. The machine can be easily loaded and moved.

Der Flexiever Mini Screener MS05 (220 V) ist ideal in Kombination mit einem Miniradlader oder einem Gelenklader. Die Maschine kann leicht geladen und bewegt werden.



## Technische Eigenschappen - Caractéristique technique - Technical Characteristics - Technische Eigenschaften

	(LxBxH) (LxLxH) (LxWxH) (LxBxH)	1250 x 1350 x 1705 mm	
	KG	250 kg	
<b>Zeeoppervlak</b> <b>Surface des tamis</b> <b>Screen area</b> <b>Siebfläche</b>		1000 x 1100 mm (1,1m <sup>2</sup> )	
<b>Zeehoek</b> <b>Angle du tamis</b> <b>Screen angle</b> <b>Siebwinkel</b>		20°	
<b>Maasopeningen</b> <b>Dimensions des mailles</b> <b>Mesh aperture</b> <b>Maschenöffnung der Netze</b>		10 / 12 - 16 - 20 - 25 - 32 - 40 - 50 mm	
		230 V - 0,3 kW	
<b>Maximum bakbreedte</b> <b>Maximum largeur godet</b> <b>Maximum bucket width</b> <b>Maximale Schaufelbreite</b>	1280 mm	<b>Storhoogte</b> <b>Hauteur de déversement</b> <b>Dump heigth</b> <b>Entladehöhe</b>	1700 mm
<b>Capaciteit</b> <b>Capacité</b> <b>Capacity</b> <b>Kapazität</b>		5 - 10 t/h	

