

Skid 2 Fracties

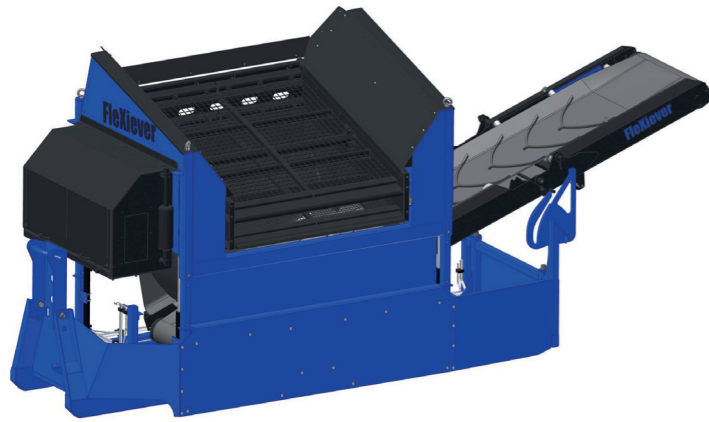

De machine heeft 1 transportband voor de afvoer van de afgezeefde grond en zal zich vooral kenmerken door het feit dat de zeefbox **hydraulisch naar omhoog** kan gezet worden. Het belangrijkste voordeel is dat de machine hierdoor onder een hoogte van 4m blijft tijdens het transport maar dat er tevens ook een hoger (groter) stortvlak gecreëerd wordt tijdens het afzeven.





La machine dispose d'une bande transporteuse pour l'enlèvement du sol tamisé et se caractérise par le fait que la trémie peut être **relevée par un mouvement hydraulique**. L'avantage le plus important est que la machine reste en dessous d'une hauteur de 4 m pendant le transport, mais aussi qu'une surface de déversement plus haute (plus grande) est créée pendant le tamisage.

The machine has 1 conveyor belt to transport the screened soil, and is distinguished primarily by the ability to **move up the screen deck hydraulically**. The main advantage of this is that the machine stays under 4 m in height for transport, but it also allows for a higher (larger) dispersal area during screening.

Die Maschine hat 1 Förderband für den Abtransport der abgeseibten Erde und kennzeichnet sich insbesondere durch die Möglichkeit, den **Siebbehälter hydraulisch nach oben zu bewegen**. Der Hauptvorteil ist, dass die Maschine dadurch beim Transport unter einer Höhe von 4 m bleibt, aber es wird beim Absieben auch ein höherer (größerer) Auffangbereich geschaffen.



Technische Eigenschappen - Caractéristique technique - Technical Characteristics - Technische Eigenschaften

 Uitgeklapt (LxBxH) Déplié (LxLxH) Unfolded (LxWxH) Entfaltete (LxBxH)	6909 x 2005 x 3078 mm		
 Ingeklapt (LxBxH) Plié (LxLxH) Folded (LxWxH) Gefaltete (LxBxH)	5200 x 2005 x 2590 mm		
 KG	4500 kg		
Zeefoppervlak Surface des tamis Screen area Siebfläche	1830 x 1830 mm		
Zeefhoek Angle du tamis Screen angle Siebwinkel	17°		
Maasopeningen Dimensions des mailles Mesh aperture Maschenöffnung der Netze	0,5 x 0,5 – 80 x 80 mm		
 Maximum bakbreedte Maximum largeur godet Maximum bucket width Maximale Schaufelbreite	2200 mm	Storthoogte Hauteur de déversement Dump height Entladehöhe	2870 mm
Capaciteit Capacité Capacity Kapazität	50 - 120 t/h		

OPTIES - OPTIONS - OPTIONS - OPTIONEN

- ELEKTROMOTOR - MOTEUR ELETRIQUE - ELECTRICAL ENGINE - ELEKTROMOTOR
- 3-FRACTIEPLAAT - SÉPARATEUR EN 3 FRACTIONS - 3-FRACTIONS FRAME - 3-FRAKTIONEN-PLATTE
- STORTBUNKER - ALIMENTATEUR - HOPPER - AUFGABEBUNKER

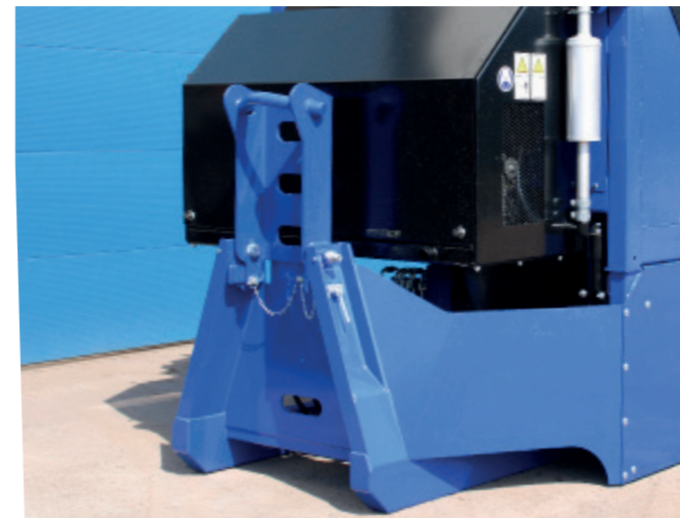

Skid 2 Fracties

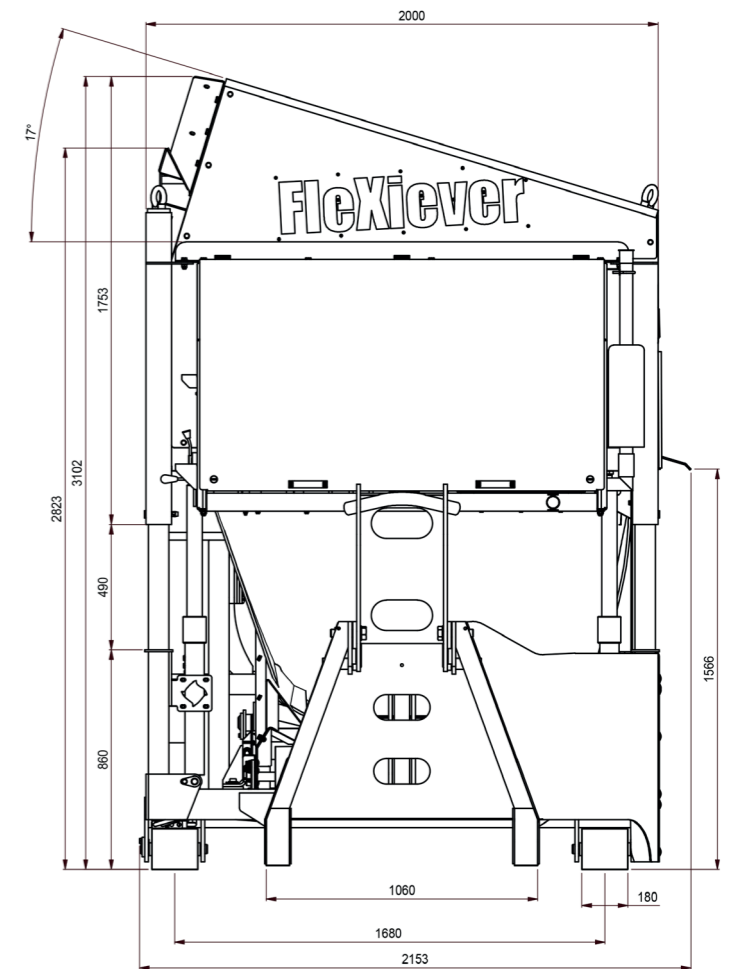
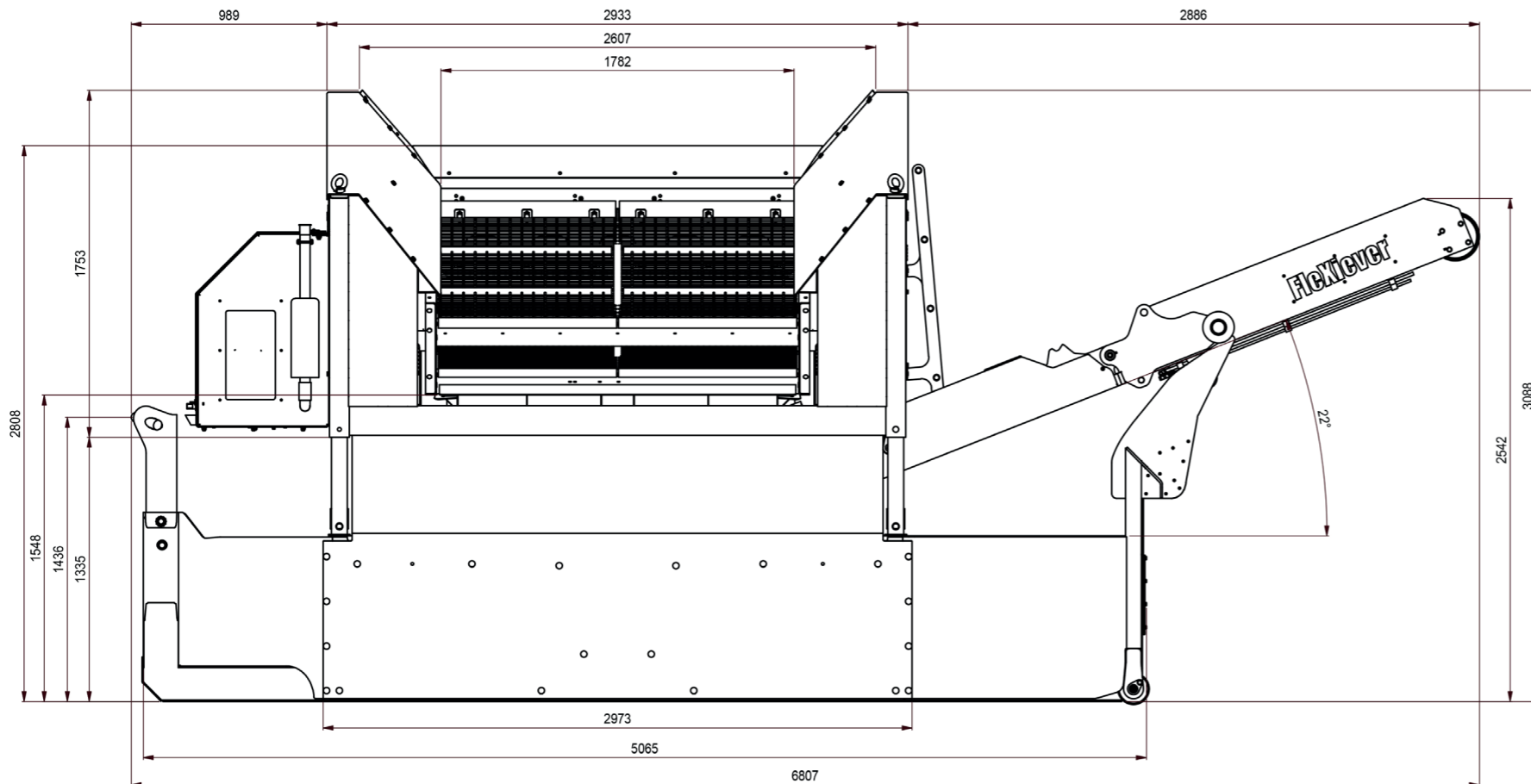
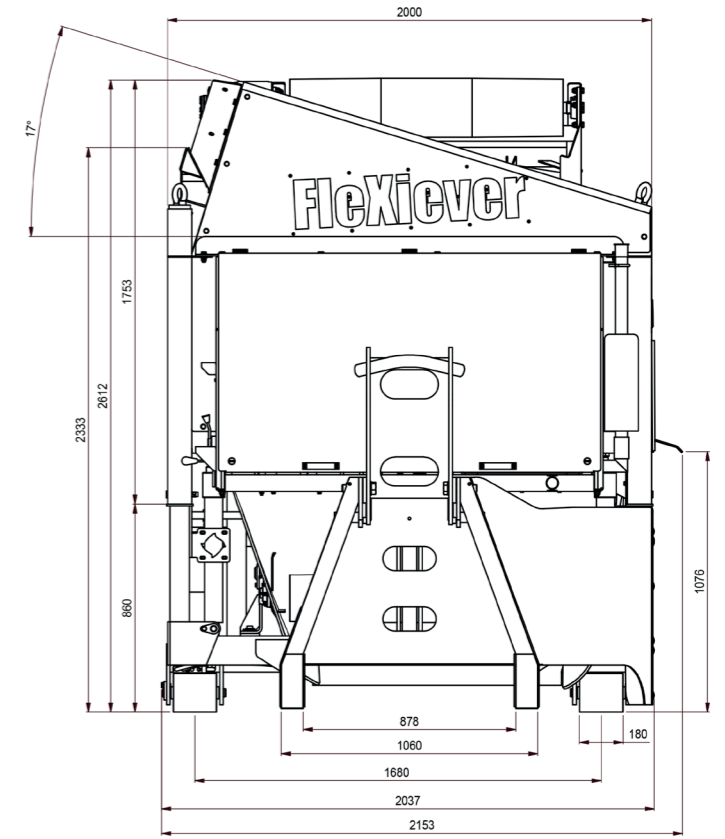
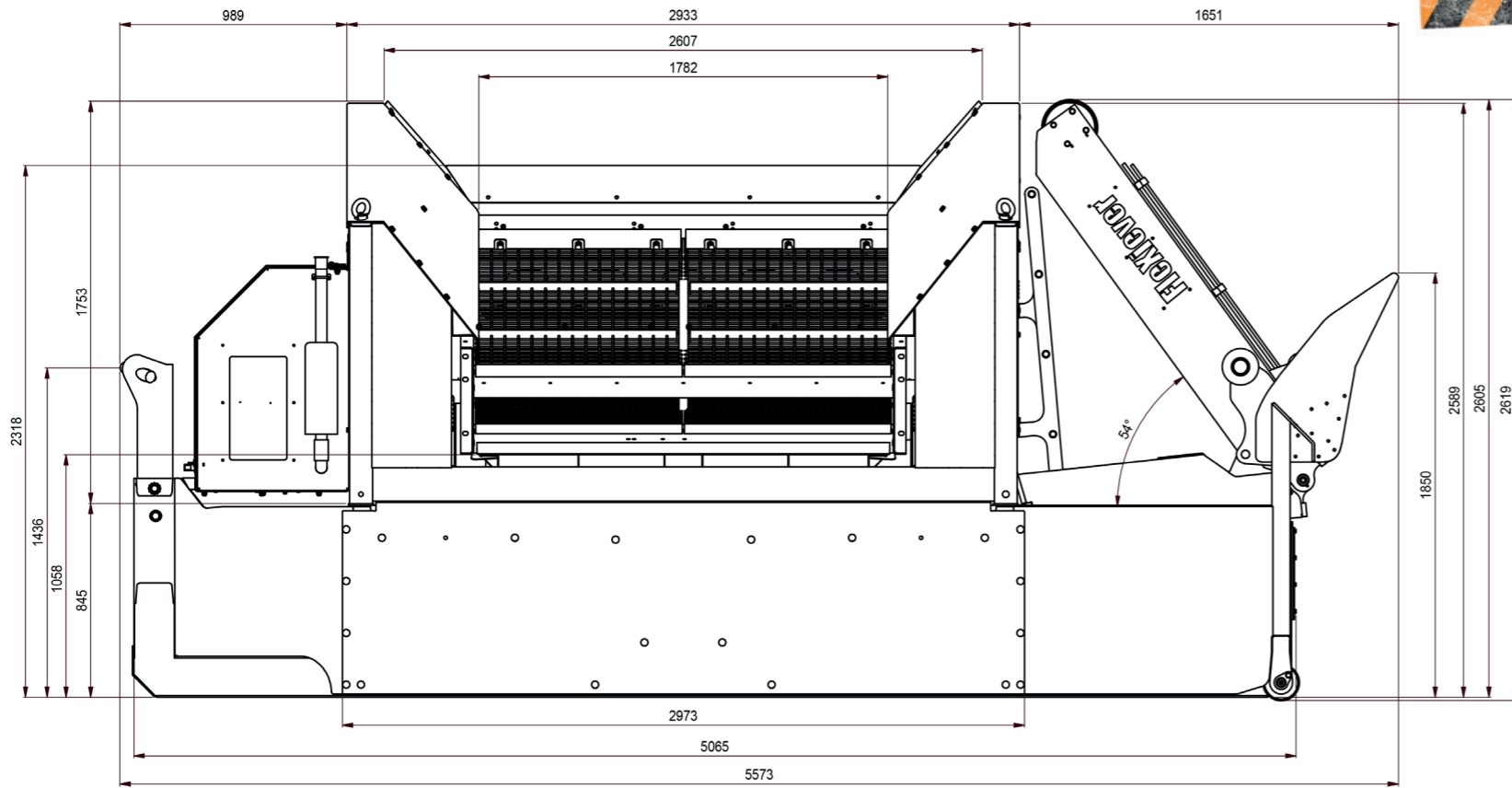

Skid 2 Fracties

Met stortbunker - avec alimentateur - with hopper - mit Aufhabebunker

