

# Mini Screener XL

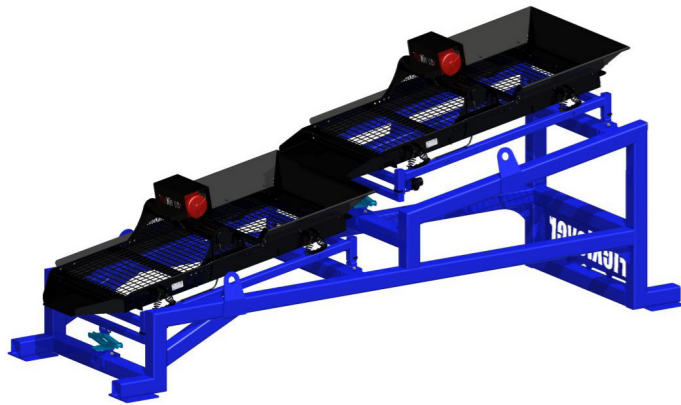

Met de Flexiever Mini Screener XL kunnen we op een creatieve en budgetvriendelijke manier verschillende oplossingen bieden. Het standaard frame bestaat uit **2 Mini Screeners die na elkaar opgesteld staan**. De hellingsgraad van de machines en de vibratie van de trilmotoren kunnen apart ingesteld worden. De maasopeningen van de zeefnetten zijn verkrijgbaar vanaf 0,5x0,5mm wat er voor zorgt dat de machine voor heel wat industriële toepassingen kan ingezet worden. Alsook kunnen de netten gemakkelijk en snel gewisseld worden.

Avec le Flexiever Mini Screener XL, nous pouvons offrir diverses solutions de manière créative et économique. Le cadre standard **se compose de 2 Mini Screeners qui sont disposés l'un après l'autre**. L'inclinaison des machines et la vibration des moteurs vibrants peuvent être réglées séparément. Les ouvertures des mailles sont disponibles à partir de 0,5 x 0,5 mm, ce qui garantit que la machine peut être utilisée pour de nombreuses applications industrielles. Les mailles peuvent également être changés rapidement et facilement.

With the Flexiever Mini Screener XL we can offer various solutions in a creative and budget-friendly way. The standard frame consists of **2 Mini Screeners that are placed one after the other**. The inclination of the machines and the vibration of the vibration motors can be set separately. The mesh openings of the screening nets are available from 0.5 x 0.5mm which ensures that the machine can be used for many industrial applications. The nets can also be changed quickly and easily.

Mit dem Flexiever Mini Screener XL sind wir in der Lage, kreativ und preisgünstig unterschiedliche Lösungen anzubieten. Das Standardgestell umfasst **2 hintereinander aufgestellte Mini Screener**. Der Neigungswinkel der Maschinen und die Vibration der Vibrationsmotoren können separat eingestellt werden. Die Siebbeläge sind mit Maschenweiten ab 0,5x0,5 mm erhältlich. Dadurch lässt sich die Maschine für eine Vielzahl von Industrieanwendungen einsetzen. Außerdem sind die Siebbeläge leicht und schnell austauschbar.



## Technische Eigenschappen - Caractéristique technique - Technical Characteristics - Technische Eigenschappen

	(LxBxH) (LxLxH) (LxWxH) (LxBxH)	4800 x 1440 x 2050 mm		
	KG	1050 kg		
<b>Zeefoppervlak</b> <b>Surface des tamis</b> <b>Screen area</b> <b>Siebfläche</b>		2x 1830 x 900 mm		
<b>Zeefhoek</b> <b>Angle du tamis</b> <b>Screen angle</b> <b>Siebwinkel</b>		Instelbaar Inclinaison réglable Adjustable Verstellbar		
<b>Maasopeningen</b> <b>Dimensions des mailles</b> <b>Mesh aperture</b> <b>Maschenöffnung der Netze</b>		0,5 x 0,5 – 80 x 80 mm		
		Trilmotor, traploos instelbaar: 230V – 0,52 kW Moteur vibrant réglable en continu: 230V - 0,52 kW Vibration motor, continuously adjustable: 230V – 0,52 kW Vibratormotor, stufenlos einstellbar: 230V - 0,52 kW		
<b>Maximum bakbreedte</b> <b>Maximum largeur godet</b> <b>Maximum bucket width</b> <b>Maximale Schaufelbreite</b>		1200 mm	<b>Storthoogte</b> <b>Hauteur de déversement</b> <b>Dump heighth</b> <b>Entladehöhe</b>	Op maat Sur mesure Tailor made Nach Maß
<b>Capaciteit</b> <b>Capacité</b> <b>Capacity</b> <b>Kapazität</b>			10 - 50 t/h	

## OPTIES - OPTIONS - OPTIONS - OPTIONEN

- STROOMGROEP - GROUPE ÉLECTROGÈNE - GENERATOR - STROMERZEUGER
- VERNEVELINSTALLATIE - KIT DE BRUMISATION - SPRAYINGSYSTEM - STAUBBINDEANLAGE

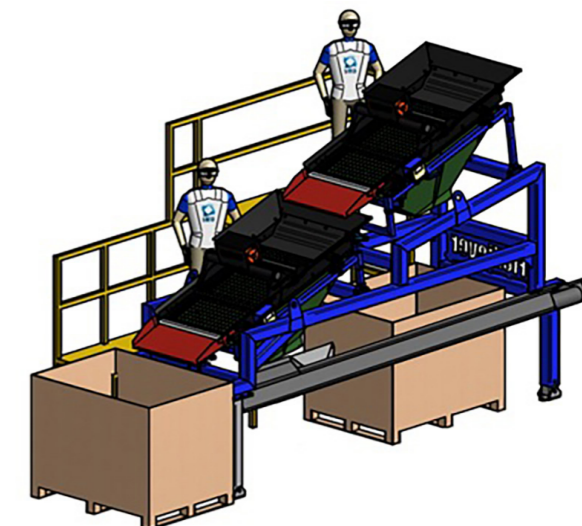
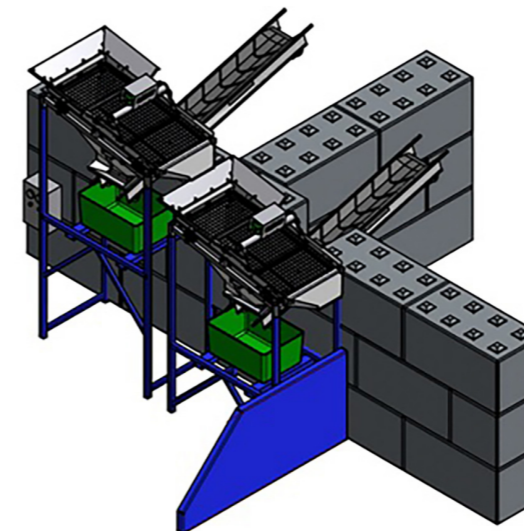

# Mini Screener XL

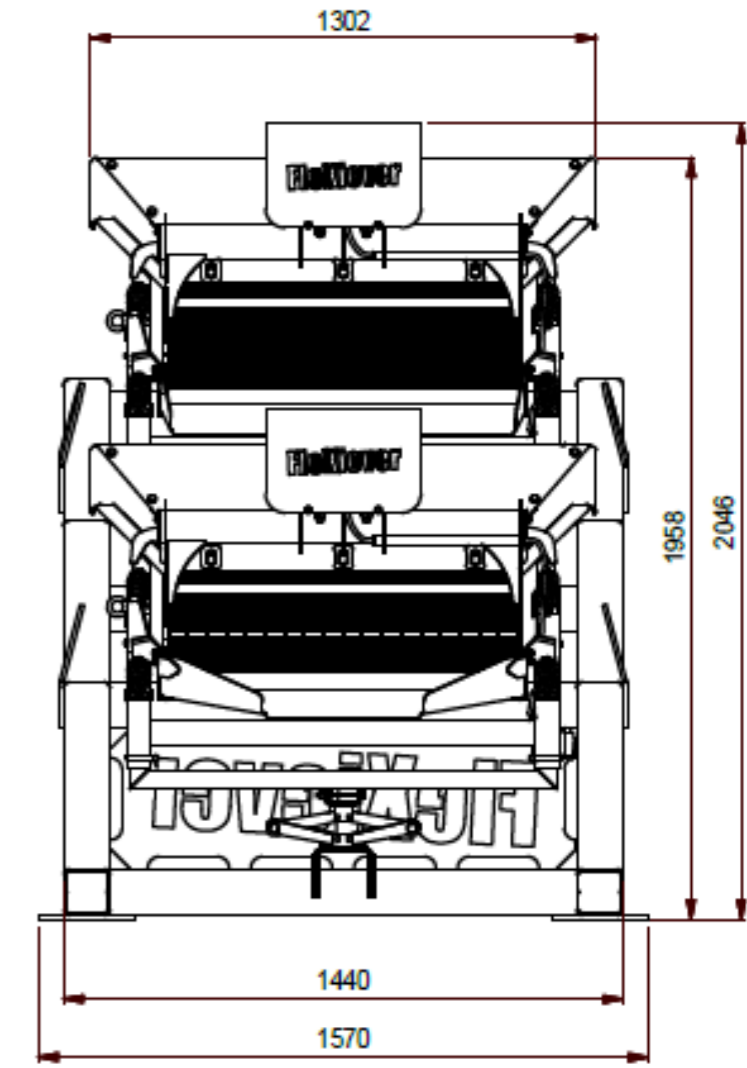
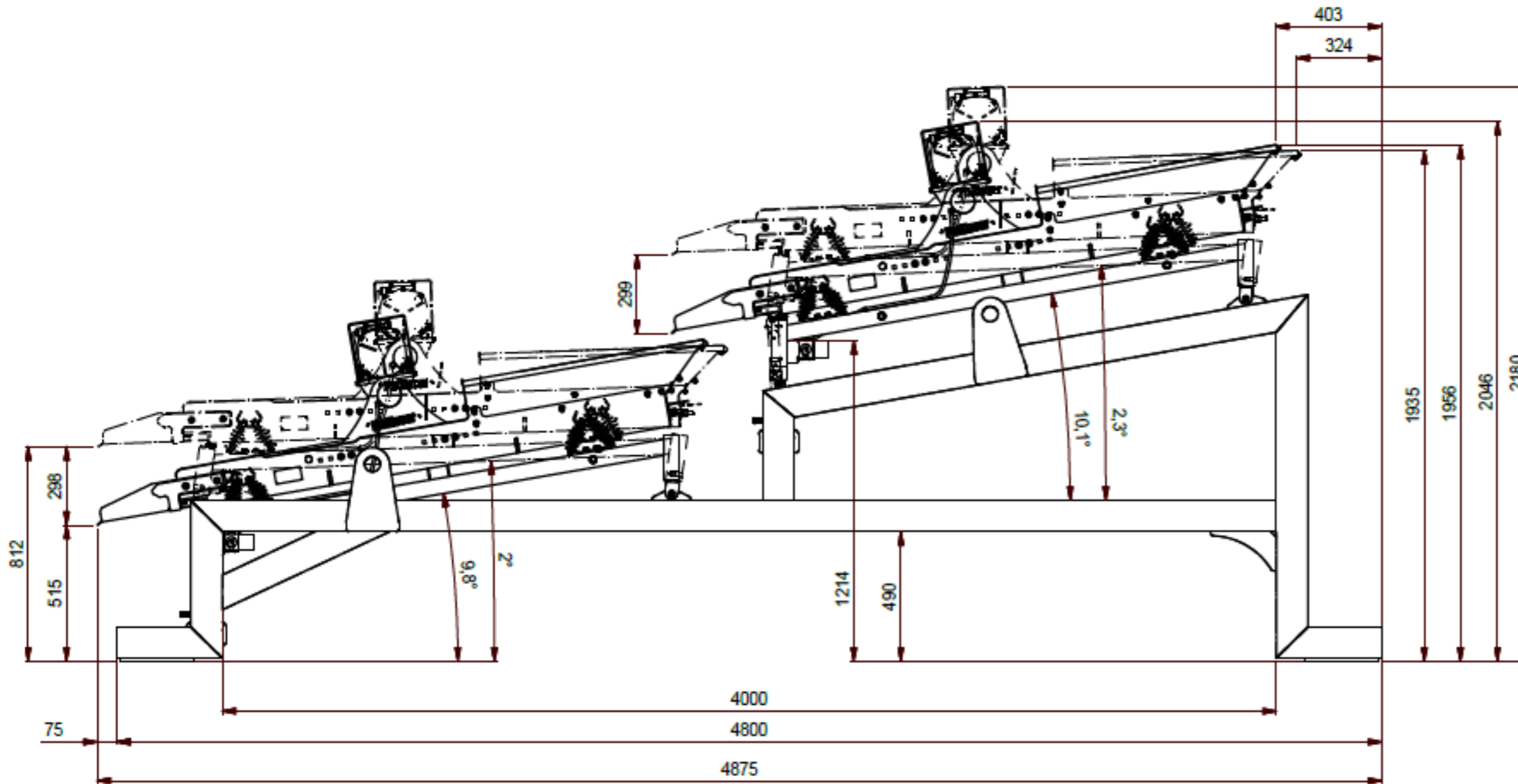

# Flexiever®

MOBILE SCREENERS

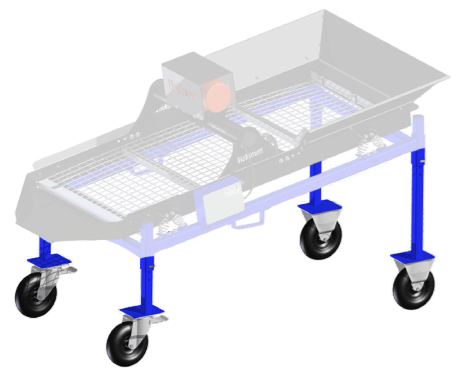

MS

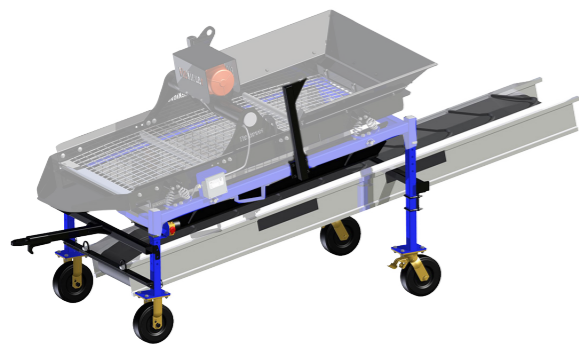

MS MC



MS Tr B

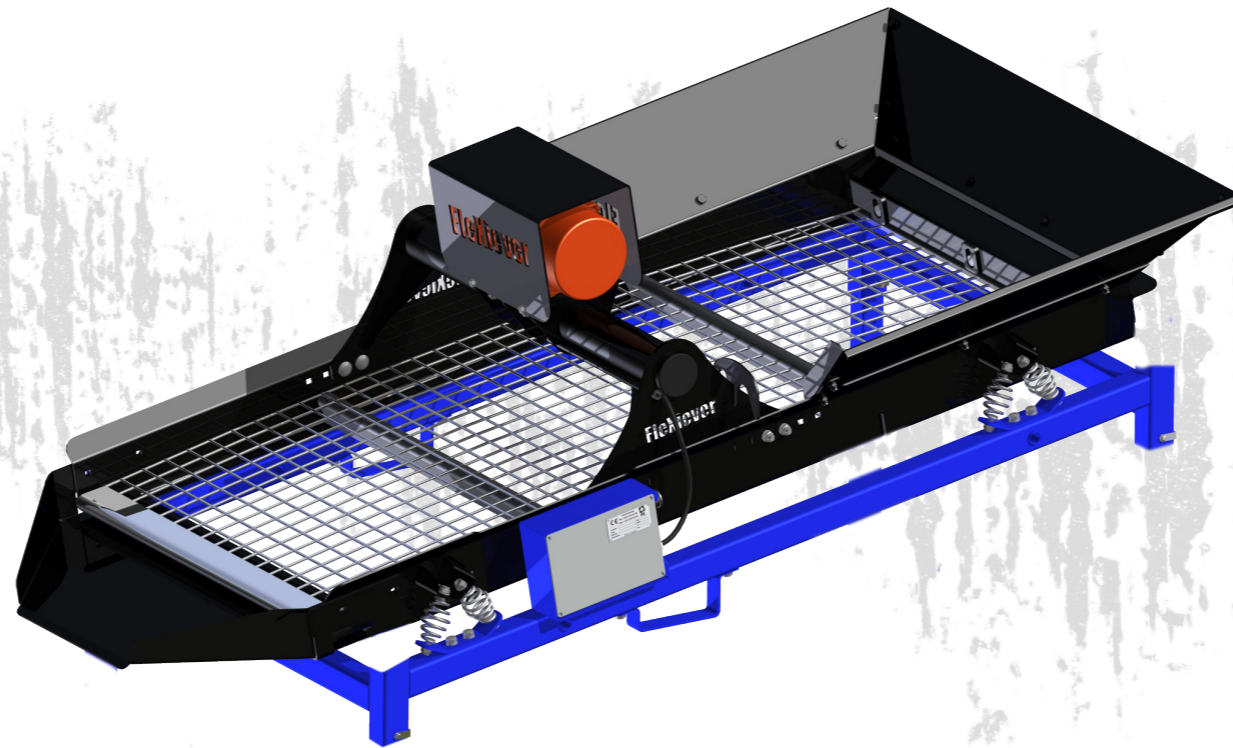

MS Tr

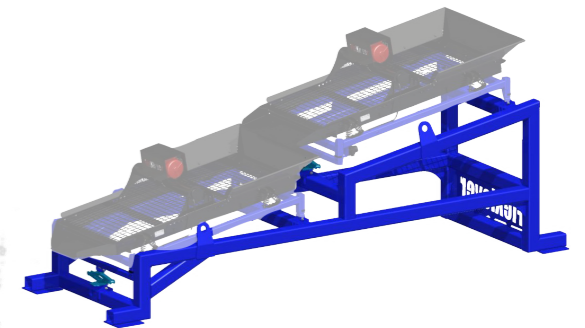

MS XL

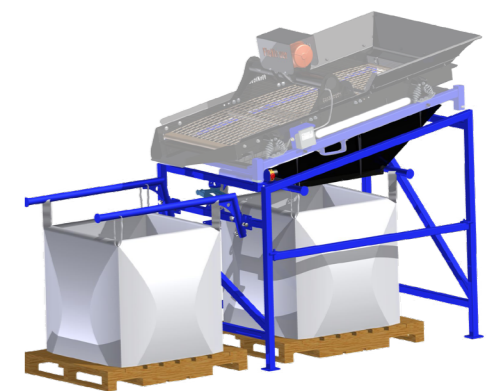

MS Big Bag

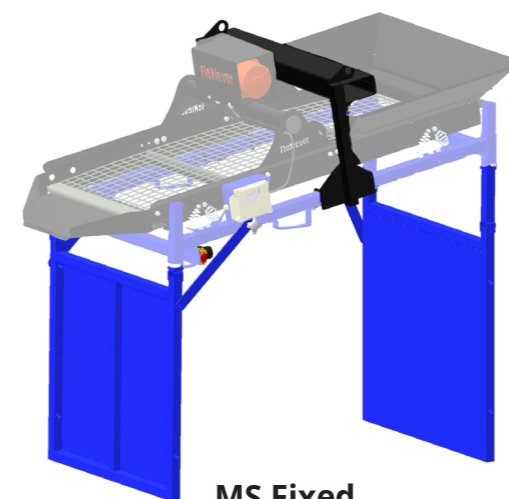

MS Fixed